



Typ USW-1 plus

Domestic hot water heater exclusively stainless steel to ANSI 316L / 316 Ti

From 150 to 1000 liter

- For use with district heating, solar, boilers, and condensing technology
- with an internal smooth pipe register
- Corrosion resistant
- Sensor terminal strips for all standard sensors of 6 to 12 mm
- Heating in the lower ground area also
- Hygienic through smooth pipe register

Designed, manufactured and tested according to DIN 4753, DIN EN 12897, and company standards in addition to PED-European Equipment Directive. Production monitored and certified by TÜV Rheinland. TIG but-welded with no crease. Complete tank dip-pickled and passivated.

Operating pressure	max. 10 bar
Operating pressure smooth pipe register	max. 25 bar
Operating temperature	max. 95° C
Operating temperature smooth pipe register	max. 200° C

Accessories - optional:

- Dipping sleeve G 1/2" made out of stainless steel ANSI 316 Ti, L = 200 mm
- Thermometer
- Flange cover with G 1 1/2" connection for electric heater
- Screw-in heater 12 kW
- Flange heater 15 kW

Insulation:

- 100 mm covered with PS-jacket
- colour RAL 9022 silver
- other colours on demand
- fire classification B2
- CE-marking
- CFC-free
- 100 % recyclable

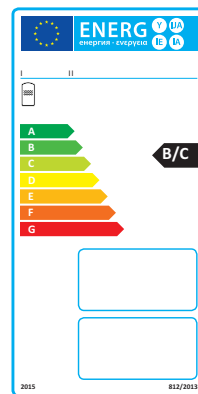

European energy label

Best Deal - STAINLESS STEEL



Head quarter:

DINOX-D®
 Edelstahlprodukte GmbH
 Im Hegen 14 a
 D-22113 Oststeinbek
 Tel. +49(0)40-71 39 09-28
 Fax +49(0)40-71 39 09-87
 info@dinox-d.de
 www.dinox-d.de

Technical Department:

D-23970 Wismar
 Tel. +49(0)38 41-303 48-0
 Fax +49(0)38 41-303 48-29
 technik@dinox-d.de



Domestic hot water heater exclusively stainless steel to ANSI 316L / 316 Ti

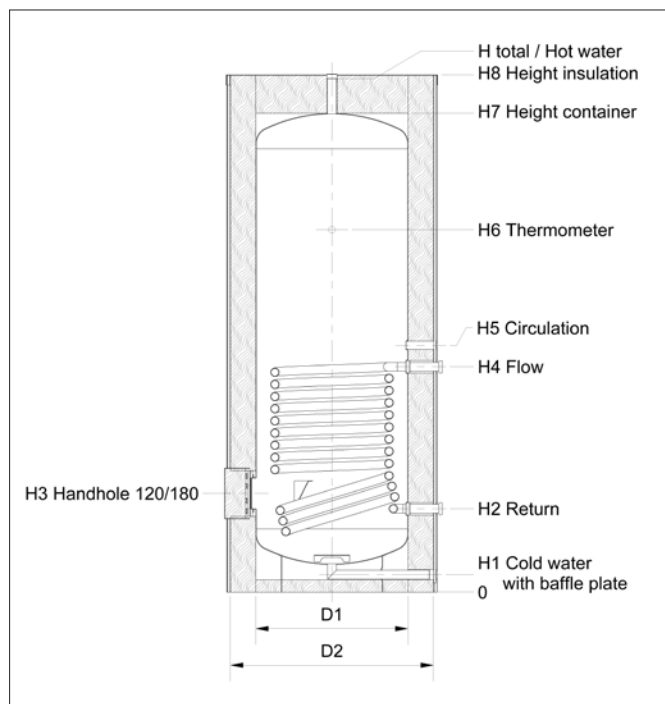

Energy related Product (ErP) Directive

Product data sheet

Acc. to (1) Commission Regulation (EU)
No 814/2013: „ecodesign requirements of“

(2) Commission delegated regulation (EU)
No 812/2013: „Energy labelling“ of
water heaters and hot water storage tanks.

- max. operating pressure: 10 bar
- max. operating pressure smooth pipe register: 25 bar
- max. operating temperature: 95° C
- max. operating temperature smooth pipe register: 200° C ***
- with an internal smooth pipe register
- all connections acc. to ISO 228-1
- Insulation:
 - 100 mm covered with PS-jacked
 - colour RAL 9022 silver
 - other colours on demand
 - fire classification B2
 - CE-marking
 - CFC free
 - 100 % recyclable
- USW1plus 150 thermostat- and thermometer connections are placed 180° offset
- subject to technical changes

Capacity	150	200	300	400	500	600	750	1000	1000
Measures in mm									
H1	65	65	65	70	70	70	80	90	80
H2	260	305	305	330	330	330	380	405	395
H3	340	365	365	390	390	390	440	465	455
H4	685	605	795	890	890	890	940	1005	995
H5	760	685	870	975	975	975	1025	1140	1090
H6	1100	1115	1345	1375	1430	1430	1480	1725	1500
H7	1296	1345	1595	1640	1890	1892	1973	2260	2006
H8	1446	1495	1745	1790	2040	2042	2123	2410	2156
H total with insulation	1450	1500	1750	1795	2045	2045	2125	2415	2160
Diagonal height without insulation ±5	1470	1520	1770	1815	2065	2065	2155	2445	2200
D1 diameter without insulation	400	500	500	600	600	650	750	800	850
D2 diameter with insulation	600	700	700	800	800	850	950	1000	1050
Weight (kg)	36	44	60	75	81	98	128	152	166
Energy efficiency class	B	B	B	B	B	B	C	C	C
Standing losses „S“ in Watt/h	41	47	56	68	78	86	102	122	119

Connections

	120/180	120/180	120/180	120/180	120/180	120/180	120/180	120/180	120/180
Inspection flange*	120/180	120/180	120/180	120/180	120/180	120/180	120/180	120/180	120/180
Cold and hot water	G 1"	G 1"	G 1"	G 1"	G 1"	G 1"	G 1½"	G 1½"	G 1½"
Circulation return	G ¾"	G ¾"	G ¾"	G ¾"	G ¾"	G ¾"	G ¾"	G ¾"	G ¾"
Thermometer	G ½"	G ½"	G ½"	G ½"	G ½"	G ½"	G ½"	G ½"	G ½"
Sensor terminal strip	3x300	3x300	3x300	3x300	3x300	3x300	3x300	3x300	3x300
Heating register	AG 1"	AG 1"	AG 1¼"	AG 1½"	AG 1½"	AG 1½"	AG 1½"	AG 1½"	AG 1½"
Heating surface in m ²	0,9	0,9	1,4	1,8	1,8	1,8	2,4	2,8	2,8

Performance data

Performance factor acc. to DIN 4708	2	4	12	20	23	26	35	46	46
Continuous Performance ** Liter/h	926	978	1522	1743	1924	2012	2413	2846	2846

* special equipment for electric heater: Flange cover with sleeve G 1½", ** during 10/80/45°C, *** Operating medium register: liquid state, not hazardous to health